

# MAG22 LED



Die-Cast Aluminium  
Well-Glass Bulkhead



**20W**

2,600  
lumens

**30W**

3,800  
lumens

**40W**

5,100  
lumens

**50W**

6,200  
lumens

**60W**

7,200  
lumens

## Hello Heavy Duty!

The MAG22 is a rugged cast aluminium well-glass bulkhead designed for demanding industrial applications. Built from marine-grade aluminium and fitted with a high thermal shock-resistant borosilicate glass lens, it offers 360° light distribution and durability in extreme conditions — including Zone 21 & 22 hazardous areas.



## Fit-For-Purpose:

- Industrial Lighting
- Outdoor Lighting
- Security Lighting
- Conveyors
- Dusty & Dirty Environments
- Foundry Lighting
- Furnace Lighting
- Low-Bay Lighting
- Zone 21 & 22

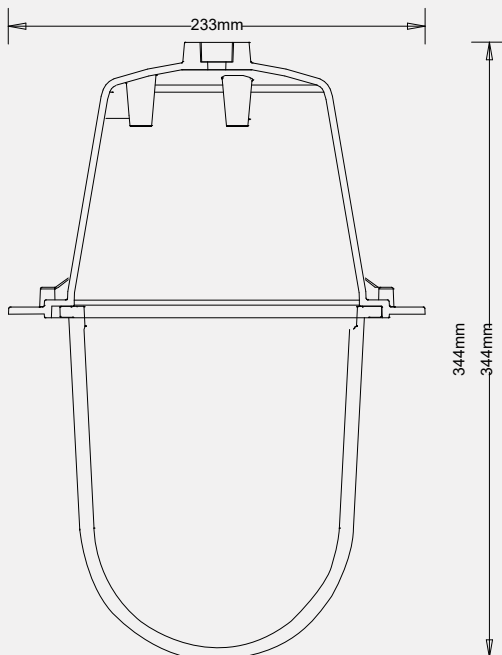

Description	Length (L)	Width (W)	Height (H)
MAG22 LED	233mm	233mm	344mm

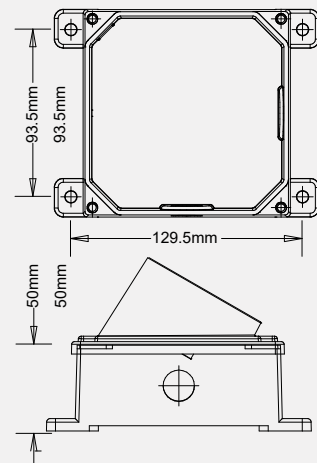
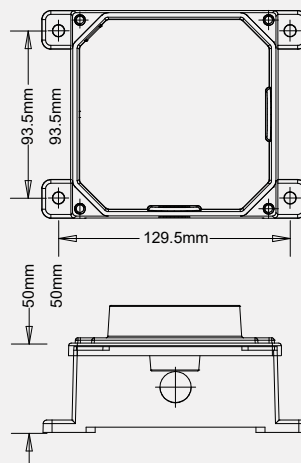

DESCRIPTION	PF	CRI	NOM. FLUX	LIFETIME	LED QTY	WEIGHT
20W CORN	>0.9	>80	2,600 lm	35 000 HR	168 PCS	5kg
30W CORN	>0.9	>80	3,800 lm	35 000 HR	240 PCS	5.2kg
40W CORN	>0.9	>80	5,100 lm	35 000 HR	340 PCS	5.2kg
50W CORN	>0.9	>80	6,200 lm	35 000 HR	440 PCS	5.3kg
60W CORN	>0.9	>80	7,200 lm	35 000 HR	540 PCS	5.3kg

## Accessory Options

SUFFIX	ACCESSORY
AV	Anti Vibration Mounting
TC	Teflon Coated
PM	Pole Mount Bracket
RG	Remote Gear Mounting
IG	Integral Gear Mounting
CR	Corrosion Resistant
EB	Eyebolt Mounting

STRAIGHT BOX

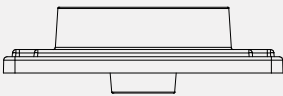

ANGLED BOX

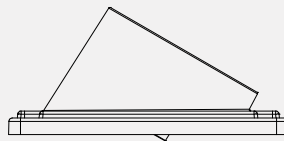

## Related Products



MAG40 LED

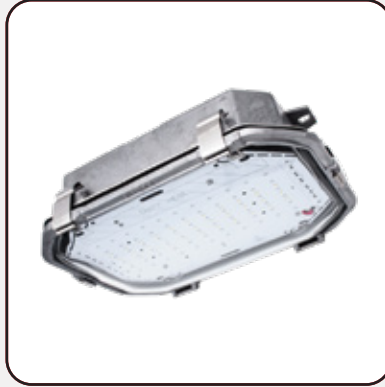

MAG44 LED



MAG45 LED



+27 11 614 4327



[lighting@ilangalighting.co.za](mailto:lighting@ilangalighting.co.za)



[www.ilangalighting.co.za](http://www.ilangalighting.co.za)



24 Julbert Road, Benrose,  
Johannesburg, 2094

A LIGHTING SOLUTION FOR **EVERY** APPLICATION!

ILANGA LIGHTING DISTRIBUTION COMPANY (PTY) LTD - REG 2003/030689/07

**B-BBEE**  
LEVEL **2**  
CONTRIBUTOR

**SABS**  
ISO 9001